

SATCOM OEM L-BAND (FABRY-PEROT LASER) FIBRE-OPTIC-LINK

PPM has produced a cost-effective Fabry-Perot laser version of its **ViaLite** OEM L-band modules for original equipment Satellite Communication product manufacturers wishing to add extra functionality to their products. The high performance, compact modules allow equipment suppliers to provide an optical interface to their RF equipment as an alternative or in addition to the traditional coaxial interface.

The use of a Fabry-Perot laser instead of a DFB laser (as used in PPM's higher performance products) makes the link ideal for more cost sensitive and short distance applications. It may be used with any PPM L-band receiver module.

Typical applications for the OEM SatCom fibre optic modules:

- Satellite Communications ground station equipment
- Up/down converters
- Modems
- HPAs
- LNBs, LNAs
- VSAT equipment

Benefits of fibre optic transmission:

The use of optical fibre has a number of inherent advantages over conventional coaxial alternatives:

- Low loss - enabling very long path lengths with minimal degradation of carrier-to-noise.
- Lightweight, highly flexible, small diameter cable.
- Frequency response is independent of path length.
- Immunity to electrical interference - the signal is not corrupted by radiated interference.
- Non-conductive - provides electrical isolation.
- Lower cost compared to coaxial cable over long distances.



Benefits of PPM's Fabry-Perot OEM SatCom fibre optic modules:

- Cost-effective Fabry-Perot laser
- Suitable for all modulation formats
- High reliability
- Compact sub-module design
- Alarm and status outputs
- Compatible 19" **ViaLite** plug-in product line

Complimentary products also available in the **ViaLite** range:

The OEM SatCom modules can be used in conjunction with optical Transmitters and Receivers from PPM's **ViaLite** 19" Plug-In product range, featuring:

- Wide-dynamic range DFB laser versions
- Timing Reference link (1-50MHz)
- 70/140MHz, L-Band, GPS fibre optic links
- Bi-directional RS422 optical data modules
- Dual redundant power supplies
- 1:1 RF redundancy switch
- 2-channel RF power splitter
- Remote alarm monitoring over fibre
- Cross site fibre optic cable solutions
- Outdoor housing solutions

For more information on PPM's range of Satellite Communication Products, see the ViaLite Accessories Datasheet at www.vialite.co.uk.

ViaLite SATCOM OEM L-BAND (FABRY-PEROT) - SPECIFICATIONS

Bandwidth

Bandwidth	<950MHz to >2150MHz
-----------	---------------------

Gain

RF Gain at 0dB optical loss	+9dB nominal when connected to matching ViaLite equipment [†] Subtract [2 x Optical Loss]dB for >0dB optical loss Optical Losses: Fibre = 0.4dB/km typ. for 1310nm Tx, 0.25dB/km typ. for 1550nm Tx Connectors = 0.5dB per connector typ.
Gain Accuracy	±1.0dB
Gain Flatness across band	±1.0dB
Gain Slope	<0.7dB / 36MHz
Receiver Gain Adjustment Range (gain adjust option only)	±3dB
Gain Stability over Temperature Tx Rx	< ±3dB over operating range <0.08dB/°C below 40°C typ., <0.1dB/°C above 40°C typ. <0.05dB/°C typ.

Dynamic Range

Input Third Order Intercept @ 1.2GHz	>+7dBm
Input P1dB @ 1.2GHz	>-3dBm
Total Input Power for -40dBc IMD @ 1.2GHz	-13dBm
Noise Figure @ 1.2GHz	<36dB, 0dB optical loss @ 1.2GHz <44dB, 12dB optical loss @ 1.2GHz
Carrier to Noise Ratio @ 1.2GHz 1MHz bandwidth, -40dBc IMD	>65dB for 0dB optical loss >57dB for <12dB optical loss

User Interface

Input/Output Impedance, VSWR	50Ω, VSWR ≤ 1.5 : 1 (14dB min.)
Transmitter Alarm Output	Monitors laser back-monitor photocurrent and laser diode forward current. Open collector alarm is raised when laser health is degraded.
Receiver Alarm Output	Monitors received light level. Open collector alarm is raised when optical loss reaches 20dB.
Open Collector Alarm Rating	+15V max. 500mA max.
Transmitter Monitor Output	Analogue measurement of laser diode forward current (IFL). This analogue output voltage monitors the efficiency of the laser diode. VIFL = 68 x Ifwd (A).
Receiver Monitor Output	Analogue measurement of received light level (RLL). The VRLL is set to give +7.75V when link gain is +9dB [†] , and varies by 0.125V/dB of RF link gain when the gain is reduced by optical path losses.
Monitor Output Range	+12V max. 0V min., maximum load 10kΩ
RF Connector	50Ω SMA Jack
Optical Connector	Suhner E2000 singlemode angle-polished connector FLSH-2000-A608
Optical Cable	0.25m pigtail, yellow jacket
LNA Feed	±36V max. 330mA max. via RF centre conductor
Supply Voltage	+12V ±0.5V
Current Consumption	Rx < 150mA, Tx < 180mA

Operating Conditions

Absolute Maximum RF Input (Tx)	>+15dBm, 5Vdc
Operating Temperature	-10°C to +50°C
Storage Temperature	-40°C to +70°C

Optical Characteristics

Wavelength	1310 ±20nm
Pigtail Fibre	Singlemode 9/125, Corning SMF28 or equivalent
Output Power	+4.5dBm/3mW nominal

All parameters specified after 15 minutes warm-up.

[†] some exceptions apply - please check with PPM

Mechanical Drawing

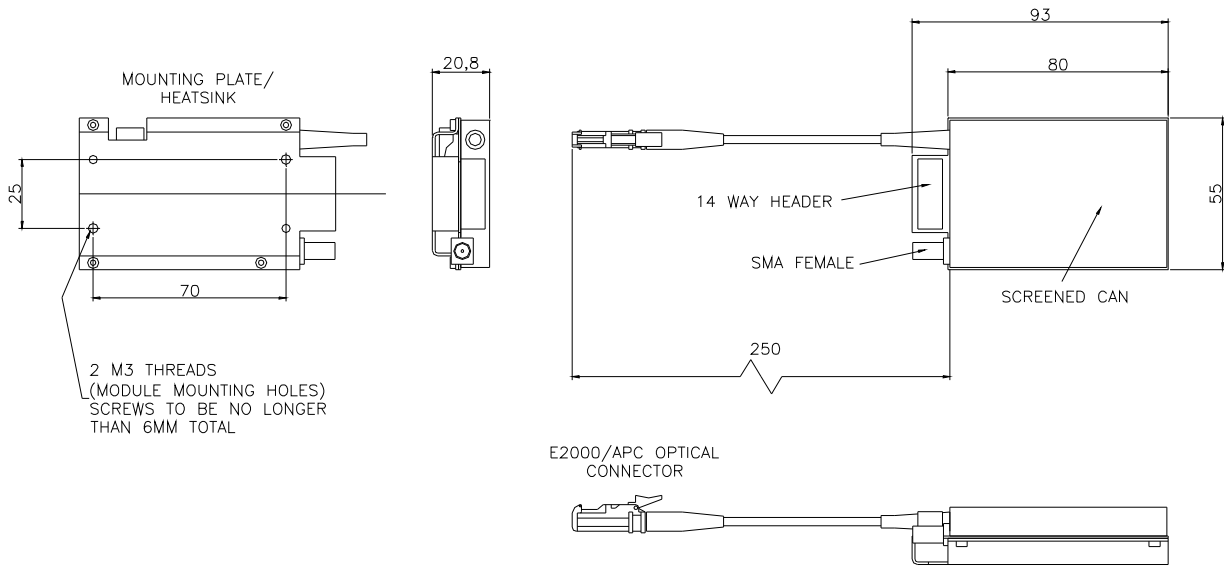

Pin Connections

Electrical connection to the module is via a 14way header *.

Pin No.	Optical Transmitter	Optical Receiver
1	Do not connect	Do not connect
2	Do not connect	Do not connect
3	Do not connect	Do not connect
4	Do not connect	Do not connect
5	Laser Alarm (Open Collector)	Low Optical Power (Open Collector)
6	Do not connect	Do not connect
7	+12V Module Power Supply	+12V Module Power Supply
8	Ground	Ground
9	Do not connect	Do not connect
10	Do not connect	Do not connect
11	Ground	Ground
12	Do not connect	Do not connect
13	LNA Feed Voltage	LNA Feed Voltage
14	Laser Current Monitor	Receiver Light Level Monitor

* Cableform is supplied with latching connector and 250mm flying leads.

Ordering Information

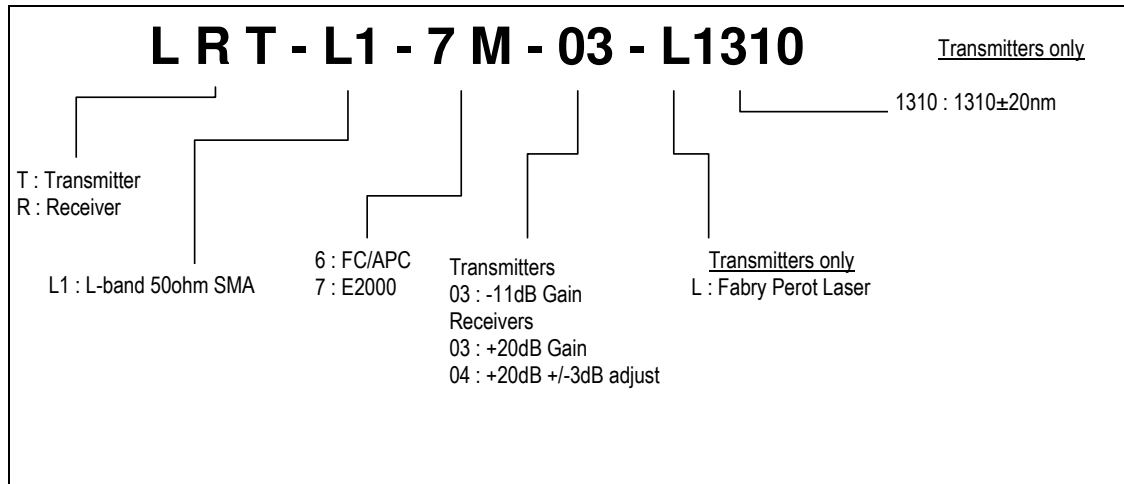

Standard parts available on short lead times:

- LRT-L1-7M-03-L1310
- LRR-L1-7M-03
- LRR-L1-7M-04

Accessories

Part Number	Description
56181	E2000 panel mounting adaptor
56172	FC/APC panel mounting adaptor
73664	Replacement Power Cable Assembly

Complementary Products

PPM offer a wide range of supporting products in OEM module and 19" rack mount formats...

- 70/140MHz, L-Band, GPS fibre optic links
- Bi-directional RS422 optical data modules
- Dual redundant power supplies
- 1:1 RF redundancy switch
- 2-channel RF power splitter
- Cross site fibre optic cable solutions
- Outdoor housing solutions
- Remote alarm monitoring over fibre
- Custom designs to suit your application



Contact Us

For further details of this or any other product from PPM, please contact us at:

PPM Ltd, 65 Shrivensham Hundred Business Park, Watchfield, Swindon, Wiltshire, SN6 8TY, UK.

Email: sales@ppm.co.uk, Tel.: +44 (0)1793 784389 Fax: +44 (0)1793 784391

Web: www.vialite.net or www.ppm.co.uk