



WIDE-DYNAMIC-RANGE 2kHz-1500MHz FIBRE-OPTIC-LINK

PPM's **ViaLite** broadband, wide dynamic range 2kHz-1500MHz Fibre-Optic-Link provides a high performance, high reliability, transparent cross-site connection between RF communications equipment.



The ultra-wide dynamic range results in negligible degradation of signals due to noise or inter-modulation effects.

The link's operation is independent of data format, and together with its inherently low phase noise performance, it is suitable for almost any type of analogue or digital signal modulation including FM and QPSK.

High reliability, comprehensive alarm & status monitoring, wide dynamic range & wide ranging gain control options result in a highly flexible product suitable for a wide range of installations.

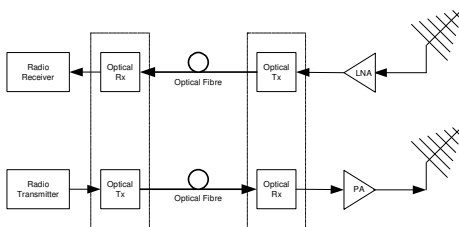

The use of optical fibre has a number of inherent advantages over conventional coaxial alternatives:

- Low loss - enabling very long path lengths with minimal degradation of carrier-to-noise.
- Lightweight, highly flexible, small diameter cable.
- Frequency response is independent of path length.
- Immunity to electrical interference - the signal is not corrupted by radiated interference.
- Non-conductive - provides electrical isolation.
- Lower cost compared to coaxial cable over long distances

PPM's **ViaLite** product offers particular advantages:

- Ultra-wide dynamic range
- Ultra-wideband operation 2kHz to 1.5GHz
- Operation from 0m to >30km
- Suitable for all modulation formats
- Compact plug-in module – up to 8 in 19" rack case
- Shielded module option for use in high levels of electrical interference or over a wide operating temperature
- Front panel status LEDs and rear panel alarm outputs: laser status, received light level
- Multiple signals on one fibre using CWDM

Complementary PPM ViaLite Products

- Alarm concentrator module
- Bi-directional RS422 optical data modules
- 19" Rack Case
- Dual redundant power supplies
- 1:1 RF Redundancy Switch
- Application specific RF modules e.g. Satellite interfacility, GPS etc.
- Ethernet Link
- Cross-site fibre optic cables

ViaLite WIDE-DYNAMIC-RANGE 2kHz-1500MHz - SPECIFICATIONS

Bandwidth

Bandwidth	<2kHz to >1500MHz
-----------	-------------------

Gain

RF Link Gain at 0dB optical loss	0dB \pm 3dB Subtract [2 x Optical Loss]dB for >0dB optical loss Optical Losses: Fibre = 0.4dB/km typ., Connectors = 0.5dB per connector typ.
Gain Flatness	+/-1dB
Gain Slope	<0.7dB/36MHz
Gain Stability over Temperature Tx Rx	< +/-3dB over operating range <0.08dB/°C below 40°C typ., <0.1dB/°C above 40°C typ. <0.05dB/°C typ.

Dynamic Range

Input Third Order Intercept	>+10dBm
Input Power for -40dBc IMD	-10dBm
Input P1dB @ 1.2GHz	>0dBm
Noise Figure @ 1.2GHz	<28dB, 0dB optical loss
Carrier to Noise Ratio 2.4kHz bandwidth, -40dBc IMD	>102dB for 0dB optical loss

User Interface

Input/Output Impedance, VSWR	50 Ω , \leq 2:1
Power LED	Indicates DC power is applied to the module
Transmitter Status LED	Green: Transmitter laser functioning Red: Transmitter laser degraded
Receiver Status LED	Green: Received light level above threshold (threshold factory set to nominal 20dB optical / 40dB electrical loss) Red: Received light level below threshold
Transmitter Alarm Outputs & Monitors	Current sink "Laser Degraded" Alarm
Receiver Alarm Outputs & Monitors	Current sink "Light Low" Alarm Analogue Received Light Level (RLL) monitor. RLL monitor voltage = 7.75V for a gain of 0dB and reduces by 0.125V per dB of RF link loss due to losses in the optical path.
RF Connector	50 Ω SMA female
External LNA Supply Voltage	+5V / +12V @ 80mA may be supplied to an external amplifier via a Bias-Tee. Contact PPM for more details.
Optical Connector options	FC/APC: Suhner FCPC-Z/M-A601 narrow keywidth connector >60dB return loss E2000/APC: Suhner FLSH-2000-A608 >60dB return loss
Monitor & Alarm Interface Rack plug-in module Shielded remote module Converter Sleeve	15pin female D-type on 19" rack case backplane 8pin female Lemo 1B 15pin female D-type
Current Consumption	Transmitter <4.5W, Receiver <4W

Operating Conditions

Absolute Maximum RF Input (RF in)	>+15dBm, 5Vdc
Optical	>60dB return loss. See above for approved connectors. Use with other types may compromise system performance.
Operating Temperature Rack plug-in module Shielded remote module	0°C to +40°C -20°C to +50°C
Storage Temperature	-40°C to +70°C

Optical Characteristics

Wavelength	1310 \pm 20nm
Fibre	Singlemode 9/125, Corning SMF28 or equivalent
Output Power	+4.5dBm/3mW nominal

All parameters specified after 15 minutes warm-up.

Physical Format

Housing Options	Rack Plug-in Module - suitable for Rack Case or Plug-in Converter Sleeve Shielded Remote Module
Supply Voltage Rack Plug-in Module Plug-in Converter Sleeve Shielded Remote Module	+12Vdc from LRK power supply +12Vdc +/-10% from external supply via 2.1mm or D-type connector +12Vdc +/-10% from external supply via Lemo 1B connector
Weight Rack plug-in module Shielded Remote Module Plug-in Converter Sleeve	600g 750g 600g + module
Rack Mount Case Suitability	LRK1S, LRK2S

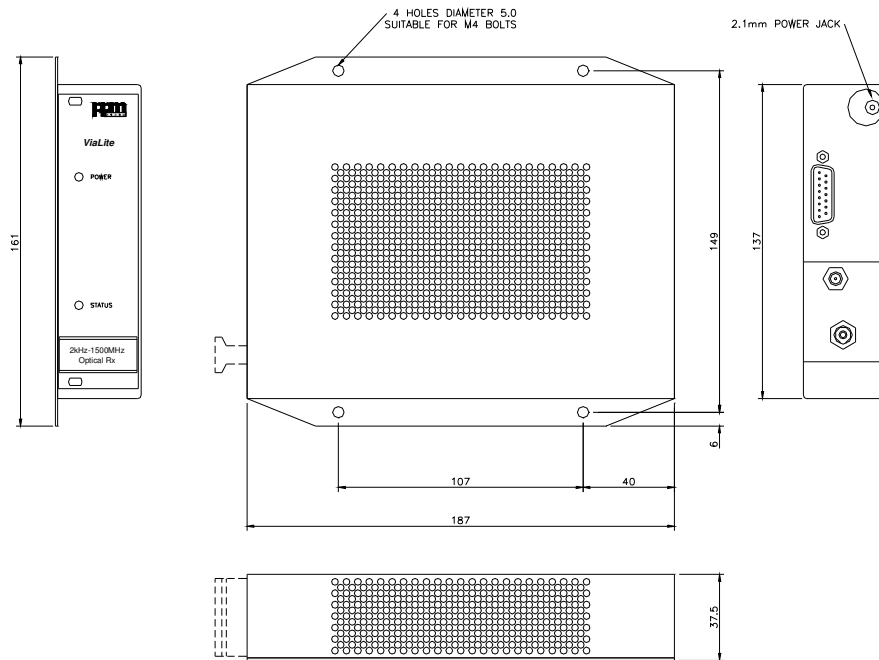

Figure 1 : Plug-in Module shown in Converter Sleeve for standalone operation

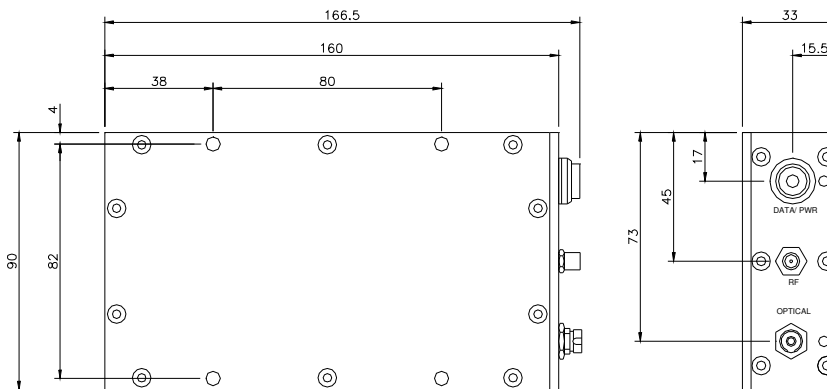
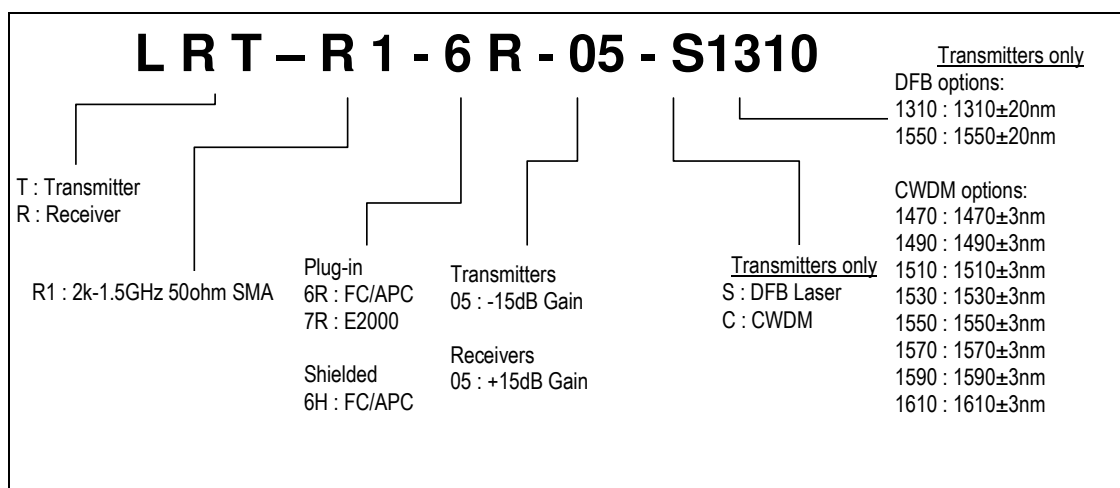

Figure 2 : Shielded Remote Module

Ordering Information



Standard parts available on short lead times:

- LRT-R1-6R-05-S1310
- LRR-R1-6R-05

19" Rack Case Solutions

Part Number	Description
LRK1S	19" Rack Case 3U for desktop or 19" rack installation. Accommodates up to 8 plug-in modules and 2 mains power supplies.
LRK2S	19" Rack Case 3U for 19" rack installation. Accommodates up to 8 plug-in modules and 2 mains power supplies.
LPS-M	Main Power Supply plug-in for LRK1S or LRK2S.
LPS-R	Reserve Power Supply plug-in for LRK1S or LRK2S.
75004	19" Rack Case, 1U for desktop or 19" rack installation, integral power supply, accommodates 3 plug-in modules.

Stand alone Solutions

75003	Converter sleeve. Converts a single plug-in module for standalone operation.
73502	Power Supply, 12Vdc, with 2.1mm connector for Plug-in Converter Sleeve
LPS-CS	Power Supply, flange mounting, 12Vdc, with 15 pin D connector for Plug-in Converter Sleeve

Accessories

Part Number	Description
LRS-10	1:1 Redundancy Switch Module
LAC-1	Alarm Concentrator Transceiver Fibre Optic Link module
F6R1/x	FC/APC Patchlead, 2.8mm jacket. Length defined in metres by "x" (1m, 2m, 10m)

CONTACT US

For further details of this or any other product from PPM, please contact us at:

PPM Ltd, 65 Shrivensham Hundred Business Park, Watchfield, Swindon, Wiltshire, SN6 8TY, UK.

Email: sales@ppm.co.uk, Tel.: +44 (0)1793 784389 Fax: +44 (0)1793 784391

Web: www.ppm.co.uk; www.vialite.co.uk